



### Frame

- Window frames are constructed of pattern grade genuine mahogany (*Swietenia macrophylla*).
- Other suitable wood species for paint, clear and stain grade applications available.
- Jamb thickness is 1 7/64" (28mm); sill thickness is 1 7/64" (28mm); depth is 6 5/8" (168mm) or milled to required project dimensions.
- Window frames are built to +/- 1/16" (1mm) tolerance.
- Frames are manufactured with dado joints and are glued and screwed for maximum strength.
- Finger jointing is not acceptable.

### Window Sash

- Window sashes are constructed of pattern grade genuine mahogany (*Swietenia macrophylla*).
- Other suitable wood species for paint, clear and stain grade applications available.
- Standard sash thickness is 2 3/16" (56mm) with sash components laminated for extra stability.
- Other window sash thickness available as required.
- Window sash widths and heights are built to +/- 1/16" (1mm) tolerance.
- Standard window sash corners are constructed with double mortise and tenon joints.
- Custom true divided lites (TDL) and/or simulated divided lites (SDL) in configurations as ordered.

### Adhesive

- All wood window components are bonded with a water resistant polyvinyl acetate industrial adhesive as manufactured by Kleiberit.

### Finish

- Undercoat and topcoat paint systems as available through Fine Paints of Europe.
- Stain and semitransparent finish systems as available through the Sikkens program.
- Other custom finishes available as required.

### Hardware

- Standard locking hardware to be a handle operated sash gear with rebate shoot bolt by GU-Hardware.
- Standard operating hinge to be Von Morris 3 1/2" x 3 1/2" plain bearing butt hinge.
- Surface mounted hardware applications available.
- Stationary or retractable screen options available.

### Weather Stripping

- Q-Ion compression gasket by Schlegel at side and head jamb stop. Double lozaron sweep seal by Schlegel at sill.
- Secondary compression gasket or metal spring type weather stripping around perimeter of sash to meet specific performance requirements.

### Glazing

- Standard insulated glass units are 3/4" (19mm) thick with a 1/2" (13mm) air space. Other thickness available as required.
- Glass options include but are not limited to: tempered, laminated, patterned, wire, spandrel, bent, restoration glass and various Low-E options.
- Standard glass units are dual sealed with polyisobutylene/polysulfide or silicone and are certified by the IGCC to meet a CBA rating.
- Glass units are blocked in glazing channel with neoprene setting blocks (70 - 90 durometer hardness).
- Glass units are wet-glazed with a high performance one part silicone sealant (neutral curing).
- Glazing channel is pressure relief vented and weeped.
- Glass is retained in glazing channel by an interior wood stop nailed or screwed in place.
- Other glazing systems available as required.

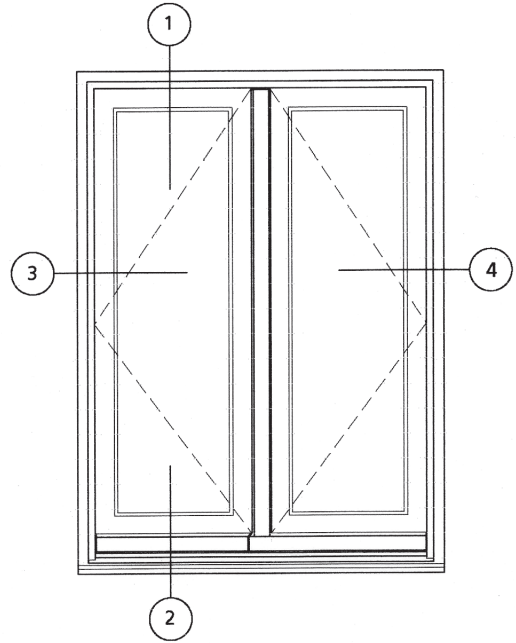
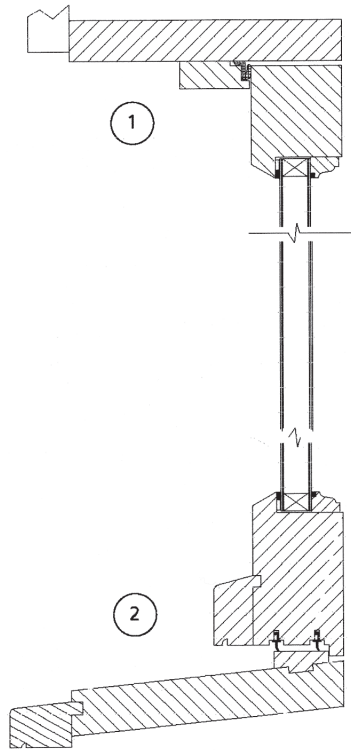

Unit type: French Casement Window  
(ext. view)

