



Frame

- Door frames are constructed of pattern grade genuine mahogany (*Swietenia macrophylla*).
- Other suitable wood species for paint, clear and stain grade applications available.
- Standard jamb thickness is 1 7/64" (28mm); interior sill thickness is 2" (50mm); depth is 6 5/8" (168mm) or milled to required project dimensions.
- Door frames are built to +/- 1/16" (1mm) tolerance.
- Frames are manufactured with dado joints and are glued and screwed for maximum strength.
- Finger jointing is not acceptable.

Door

- Stile and rail doors are constructed of pattern grade genuine mahogany (*Swietenia macrophylla*).
- Other suitable wood species for paint, clear and stain grade applications available.
- Doors have 2 3/16" (56mm) thick stave core construction stiles and rails with book matched 1/4" (6mm) thick face veneers.
- Other door thickness available as required.
- Door widths and heights are built to +/-1/16" (1mm) tolerance.
- Standard door corners are coped and dowelled.
- Back to back wood panels with a moisture barrier in configurations as ordered.
- Custom true divided lites (TDL) and/or simulated divided lites (SDL) in configurations as ordered.

Adhesive

- All wood door components are bonded with a water resistant polyvinyl acetate industrial adhesive as manufactured by Kleiberit.

Finish

- Undercoat and topcoat paint systems as available through Fine Paints of Europe.
- Stain and semitransparent finish systems as available through the Sikkens program.
- Other custom finishes available as required.

Hardware

- Standard hardware to be HLS9000 stainless steel manual lever operated multipoint locking system as manufactured by Hoppe.
- Standard hinge to be extruded brass ball bearing 4 1/2" x 4 1/2" butt hinge as manufactured by Von Morris.
- Other suitable hardware and hinge applications available.
- Screen/storm doors or retractable screen options available.

Weather Stripping

- Q-Ion compression gasket by Schlegel at side and head jamb stop. Double lozaron sweep seal by Schlegel at sill.
- Secondary compression gasket or metal spring type weather stripping around perimeter of door to meet specific performance requirements.

Glazing

- Standard tempered insulated glass units are 3/4" (19mm) thick with a 1/2" (13mm) air space. Other thickness available as required.
- Glass options include but are not limited to: laminated, patterned, wire, spandrel, bent, restoration glass and various Low-E options.
- Standard glass units are dual sealed with polyisobutylene/polysulfide or silicone and are certified by the IGCC to meet a CBA rating.
- Glass units are blocked in glazing channel with neoprene setting blocks (70 - 90 durometer hardness).
- Glass units are wet-glazed with a high performance one part silicone sealant (neutral curing).
- Glazing channel is pressure relief vented and weeped.
- Glass is retained in glazing channel by an interior wood stop nailed or screwed in place.
- Other glazing systems available as required.

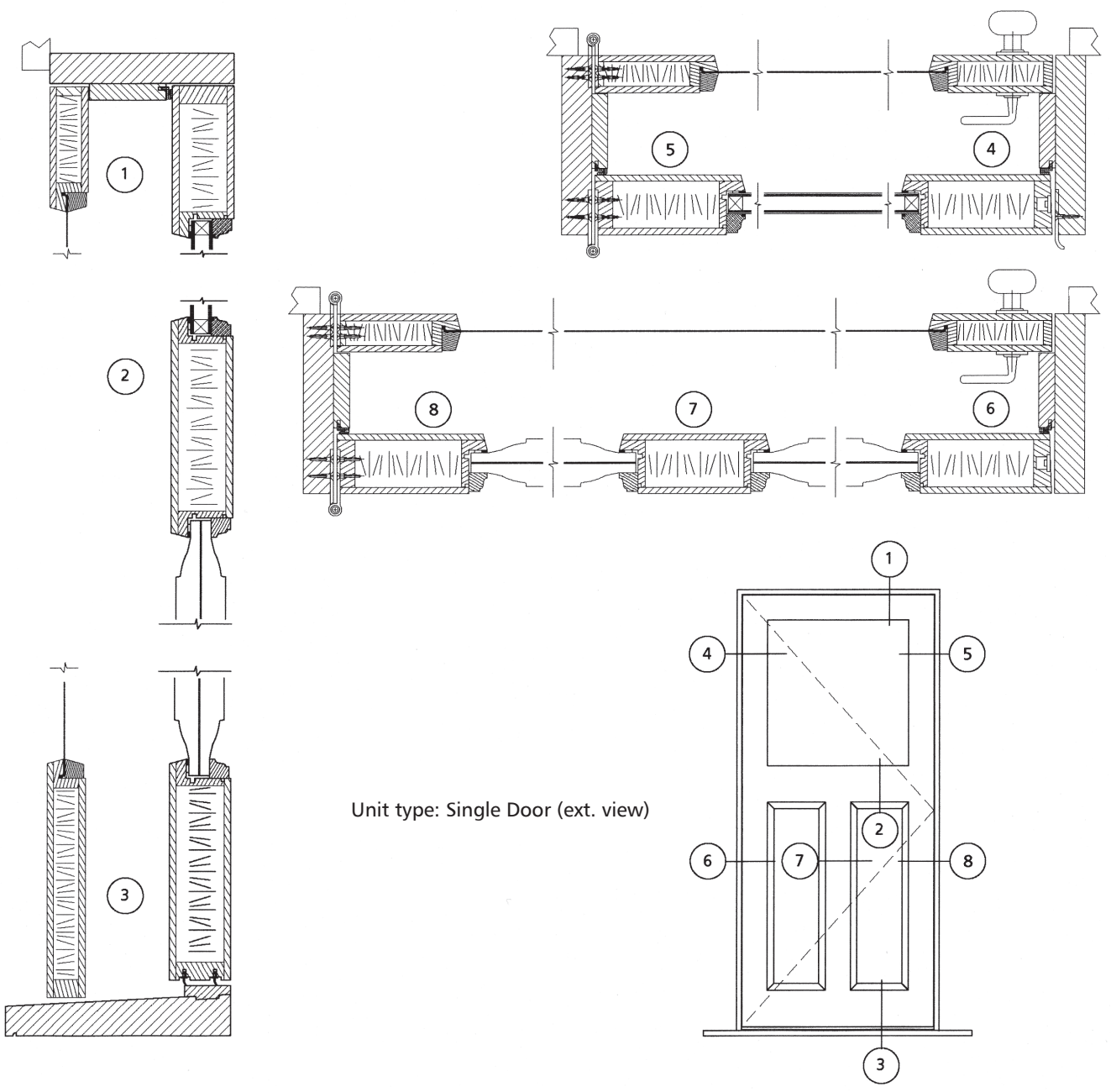

Unit type: Single Door (ext. view)